

SORTIERGREIFER MB-G1200 S4

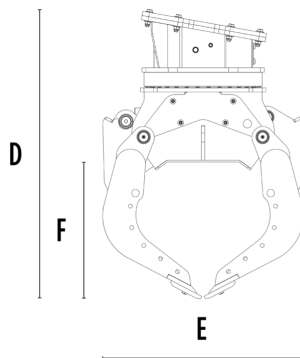
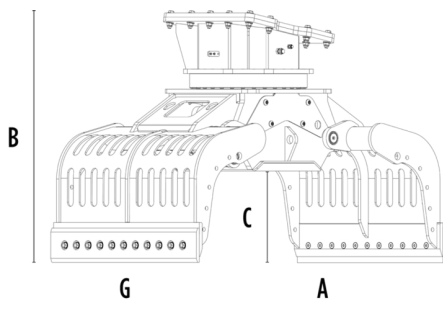

TECHNISCHE EIGENSCHAFTEN

Empfohlener Bagger	lb	39,680 - 66,140
Gewicht	lb	3,637
Volumen (geschlossene Schalen)	cy	0.93
Rotation	Degree	360°
Benötigter Arbeitsdruck (Rotation)	PSI	2,901 - 3,626
Öldurchfluss (Rotation)	gal/min	8 - 11
Benötigter Arbeitsdruck max. (öffnen/schließen)	PSI	4,351 - 5,076
Öldurchfluss max. (öffnen/schließen)	gal/min	18 - 24
Abmessung A	in	83
Abmessung B	in	57
Abmessung C	in	23
Abmessung D	in	66
Abmessung E	in	47
Abmessung F	in	32
Abmessung G	in	49

ZUBEHÖR

Schneidmesser-Kit mit Zähnen	Kit Schalenabdeckung
Kit-Grifverbesserung des Schaleninneren	Hebe-Kit mit Gummiprofilen
Drehkraftvervielfältigungs-Kit	Elektro-Kit (für Zwei-Schlauch-Funktionalität) 12 V
Remote power control system	24-monatige Garantie

ANWENDUNGSBEREICHE



Abrisse



Strassenarbeiten



Steinbrüche



Minen



Tunnel



Geschlossene Umgebungen



Kanalisation



Städtische Baustellen



Pflege von Grün- und Landwirtschaftsflächen



Pflege von Waldgebieten

