

GODET CONCASSEUR MB-C50 S4

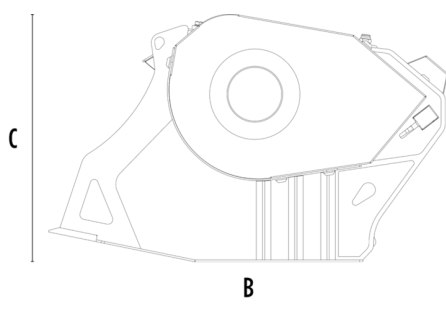

CARACTÉRISTIQUES TECHNIQUES

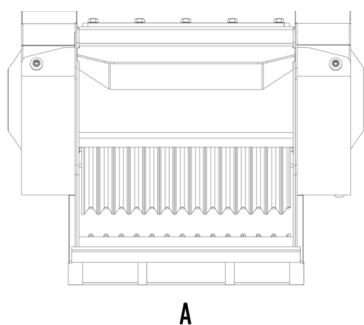

Pelle hydraulique recommandée

tonne

6,5 - 10



Tractopelle recommandée

tonne

8 - 9*

Poids

tonne

0,75

Capacité de charge

m³

0.15

Pression

bar

200 - 250

Contre-pression

bar

< 10

Débit d'huile**

l/min

90 - 120

Largeur de la bouche

mm

590

Hauteur de la bouche

mm

280

Dimension A

mm

1000

Dimension B

mm

1240

Dimension C

mm

770

* Installable uniquement sur le bras arrière de la chargeuse-pelleteuse.

** La valeur du débit hydraulique minimum doit être obtenue en même temps que la pression du travail demandée.

OPTIONS

Brumisateur

Compteur

DOMAINES D'APPLICATION



Démolitions



Travaux routiers



Tunnels



Lieux clos



Canalisations



Recyclage des déchets
inertes



Chantiers urbains



Entretien des zones
forestières

