

SORTIERGREIFER MB-G600 S4

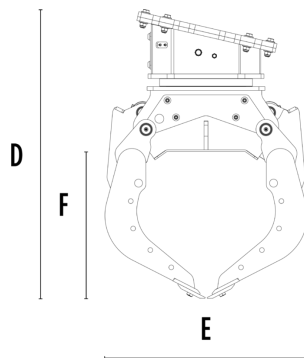

TECHNISCHE EIGENSCHAFTEN

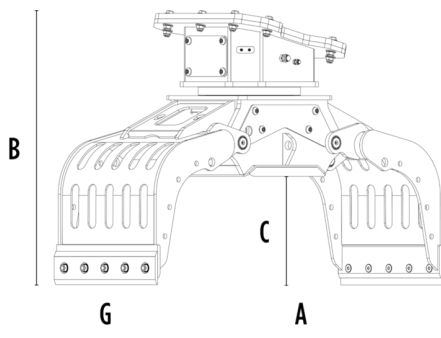

Empfohlener Bagger	t	7 - 12
Gewicht	t	0,63
Volumen (geschlossene Schalen)	m ³	0,24
Rotation	Grad	360°
Benötigter Arbeitsdruck (Rotation)	bar	160 - 200
Öldurchfluss (Rotation)	l/min	25 - 35
Benötigter Arbeitsdruck max. (öffnen/schließen)	bar	250 - 300
Öldurchfluss max. (öffnen/schließen)	l/min	50 - 60
Abmessung A	mm	1705
Abmessung B	mm	1145
Abmessung C	mm	470
Abmessung D	mm	1300
Abmessung E	mm	975
Abmessung F	mm	625
Abmessung G	mm	650

ZUBEHÖR

Schneidmesser-Kit mit Zähnen	Kit Schalenabdeckung
Kit-Seitenabdeckung mit Zähnen	Kit-Greifverbesserung des Schaleninneren
Hebe-Kit mit Gummiprofilen	Drehkraftvervielfältigungs-Kit
Elektro-Kit(für Zwei-Schlauch-Funktionalität) 12 V	Remote power control system
24-monatige Garantie	

ANWENDUNGSBEREICHE



Abrisse



Strassenarbeiten



Steinbrüche



Minen



Tunnel



Geschlossene Umgebungen



Kanalisierung



Städtische Baustellen



Pflege von Grün- und Landwirtschaftsflächen



Pflege von Waldgebieten