

PINZA SELEZIONATRICE MB-G1500 S4

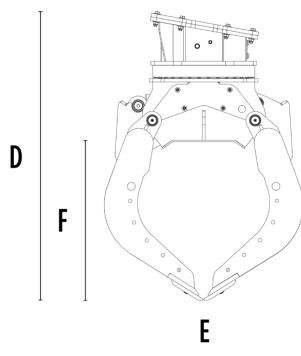
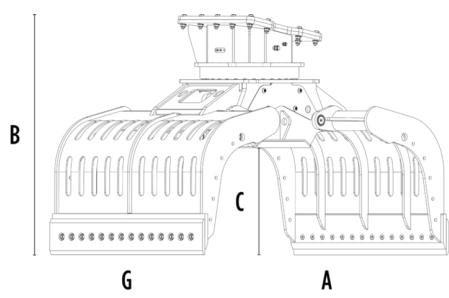

CARATTERISTICHE TECNICHE

Escavatore consigliato	ton	20 - 30
Peso	ton	2,05
Capacità (chele chiuse)	m ³	1,43
Rotazione	Grado	360°
Pressione d'olio (rotazione)	bar	200 - 250
Portata d'olio (rotazione)	l/min	30 - 40
Pressione d'olio massima (apertura - chiusura)	bar	300 - 350
Portata d'olio massima (apertura - chiusura)	l/min	70 - 90
Dimensione A	mm	2480
Dimensione B	mm	1650
Dimensione C	mm	810
Dimensione D	mm	1950
Dimensione E	mm	1365
Dimensione F	mm	1110
Dimensione G	mm	1535

ACCESSORI OPZIONALI

Kit lame multifunzione	Kit copertura contenimento chele
Kit miglioramento presa interno chele	Kit sollevamento basculante con profili in gomma
Kit moltiplicatore di forza rotazione	Kit elettrico (per funzionalità due tubi) 12 V
Remote power control system	Garanzia 24 mesi

AREE DI APPLICAZIONE



Demolizioni



Lavori stradali



Cave



Miniere



Gallerie



Ambienti chiusi



Canalizzazioni



Cantieri urbani



Manutenzione aree verdi e agricole



Manutenzione aree forestali

