

# GODET CONCASSEUR BF120.4 S4

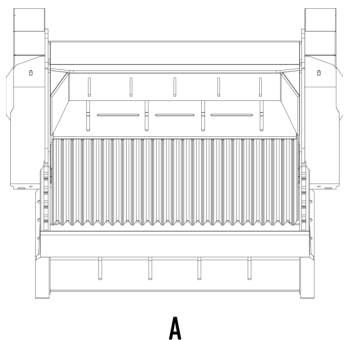

A

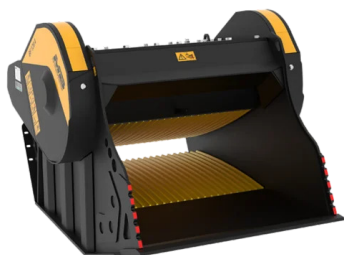
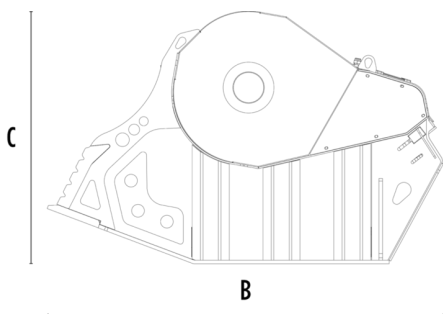

B

## CARACTÉRISTIQUES TECHNIQUES



Pelle hydraulique recommandée	tonne	30 - 45
Poids	tonne	4,8
Capacité de charge	m <sup>3</sup>	1,3
Pression	bar	220 - 280
Contre-pression	bar	< 10
Débit d'huile*	l/min	190 - 250
Largeur de la bouche	mm	1205
Hauteur de la bouche	mm	540
Dimension A	mm	1620
Dimension B	mm	2185
Dimension C	mm	1390

\* La valeur du débit hydraulique minimum doit être obtenue en même temps que la pression du travail demandée.

## OPTIONS

Brumisateur	Compteur
Électro aimant 24 V	

## DOMAINES D'APPLICATION



Démolitions



Travaux routiers



Carrières



Mines



Tunnels



Lieux clos



Canalisations



Recyclage des déchets inertes



Chantiers urbains



Fonderies



Entretien des zones forestières

