

PINCE DE TRI

MB-G450 S4

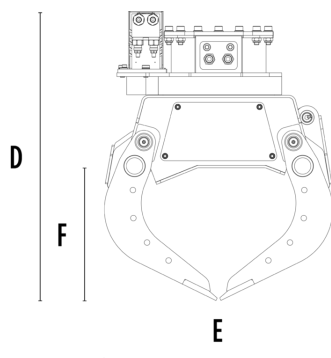

CARACTÉRISTIQUES TECHNIQUES

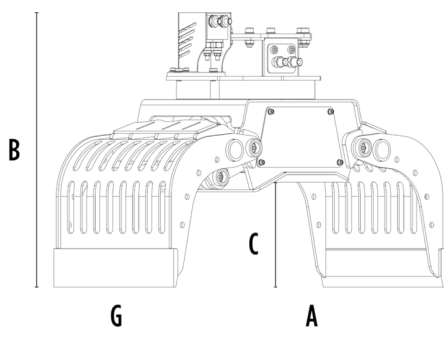

Pelle hydraulique recommandée	tonne	3,5 - 5,5
Poids	tonne	0,288
Capacité (griffes fermées)	m ³	0,10
Rotation	Degrés	360°
Pression d'huile (rotation)	bar	150 - 200
Débit d'huile (rotation)	l/min	10 - 20
Pression d'huile maximale (ouverture - fermeture)	bar	180 - 220
Débit d'huile maximum (ouverture - fermeture)	l/min	20 - 30
Dimension A	mm	1300
Dimension B	mm	865
Dimension C	mm	425
Dimension D	mm	960
Dimension E	mm	770
Dimension F	mm	520
Dimension G	mm	475

OPTIONS

Kit de lames multifonctions	Kit benne preneuse
Kit plaque latérale dentée	Kit amélioration préhension interne
Kit soulèvement basculant avec profils en caoutchouc	Kit inverseur électrique (nécessaire pour pelle ayant 1 seule ligne) 12 V
Garantie de 24 mois	

DOMAINES D'APPLICATION



Démolitions



Travaux routiers



Tunnels



Lieux clos



Canalisations



Chantiers urbains



Entretien des espaces
verts et agricoles



Entretien des zones
forestières