

SORTEERGRIJPER MB-G1200 S4

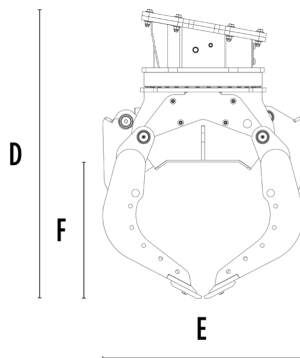
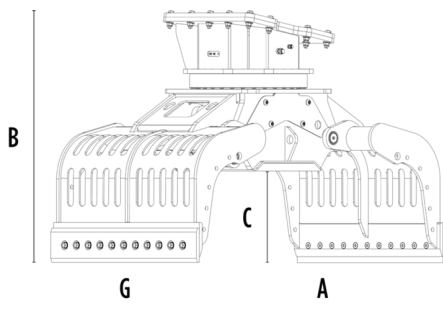

TECHNISCHE EIGENSCHAPPEN

Aanbevolen graafmachine	ton	18 - 30
Eigen gewicht	ton	1,65
Inhoud (gesloten schalen)	m ³	0,71
Rotatie	Graden	360°
Werkdruk (rotatie)	bar	200 - 250
Olieflow (rotatie)	l/min	30 - 40
Werkdruk max. (openen - sluiten)	bar	300 - 350
Olieflow max. (openen - sluiten)	l/min	70 - 90
Afmeting A	mm	2115
Afmeting B	mm	1450
Afmeting C	mm	590
Afmeting D	mm	1670
Afmeting E	mm	1185
Afmeting F	mm	810
Afmeting G	mm	1235

OPTIONELE ACCESSOIRES

Onderschroefmessen met tanden en glad mes, omkeerbaar	Set platen om schalen dicht te maken
Opschroefblokken met tanden voor extra grip binnenkant	Zelfpositionerende klemrubbers
Rotatiekracht versterker	Electrisch bediend wisselventiel om roteren en openenen/sluiten via één extra functie te bedienen, 12 V
Remote power control system	

TOEPASSINGEN

 Sloopwerkzaamheden	 Wegenbouw	 Groeven	 Mijnen	 Tunnelbouw
 Krappe ruimtes	 Leiding- en kabelwerken	 Binnenstedelijke bouwplaatsen	 Omgevingswerken	 Bosonderhoud

