

# PINCE DE TRI MB-G600 S4

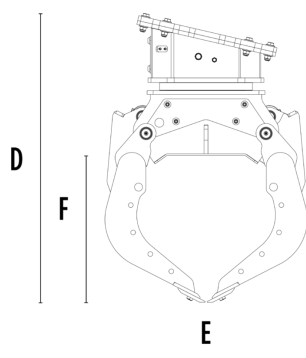
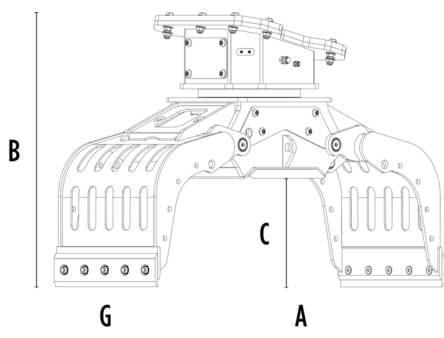

## CARACTÉRISTIQUES TECHNIQUES

Pelle hydraulique recommandée	lb	15,430 - 26,460
Poids	lb	1,389
Capacité (griffes fermées)	cy	0.31
Rotation	Degree	360°
Pression d'huile (rotation)	PSI	2,321 - 2,901
Débit d'huile (rotation)	gal/min	7 - 9
Pression d'huile maximale (ouverture - fermeture)	PSI	3,626 - 4,351
Débit d'huile maximum (ouverture - fermeture)	gal/min	13 - 16
Dimension A	in	67
Dimension B	in	45
Dimension C	in	19
Dimension D	in	51
Dimension E	in	38
Dimension F	in	25
Dimension G	in	26

## OPTIONS

Kit de lames multifonctions	Kit benne preneuse
Kit plaque latérale dentée	Kit amélioration préhension interne
Kit soulèvement basculant avec profils en caoutchouc	Kit multiplicateur de force de rotation
Kit inverseur électrique (nécessaire pour pelle ayant 1 seule ligne) 12 V	Remote power control system
Garantie de 24 mois	

## DOMAINES D'APPLICATION



Démolitions



Travaux routiers



Carrières



Mines



Tunnels



Lieux clos



Canalisations



Chantiers urbains



Entretien des espaces  
verts et agricoles



Entretien des zones  
forestières

