

CRUSHER BUCKET MB-C50 S4

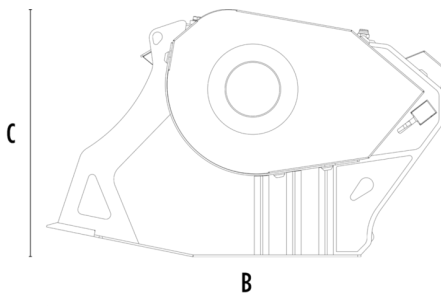

SPECIFICATIONS

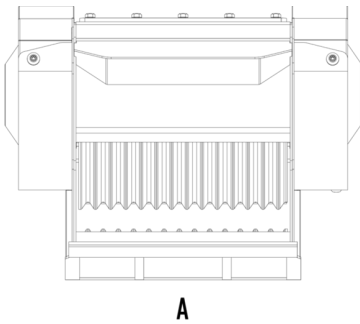

Recommended excavator	ton	6,5 - 10
Recommended backhoe loader	ton	8 - 9*
Weight	ton	0,75
Load capacity	m ³	0.15
Pressure	bar	200 - 250
Back pressure	bar	< 10
Oil flow rate**	l/min	90 - 120
Mouth width	mm	590
Mouth height	mm	280
Size A	mm	1000
Size B	mm	1240
Size C	mm	770

* Applicable only on the rear arm of the backhoe.

** The minimum hydraulic flow rate value must be alongside the required operating pressure

OPTIONAL ACCESSORIES

Dust suppression kit

Hour meter

APPLICATION AREAS



Demolitions



Road works



Tunnels



Enclosed spaces



Pipelines



Inert material recycling



Urban construction site



Forest Maintenance

