

# SORTING GRAPPLE

# MB-G1200 S4

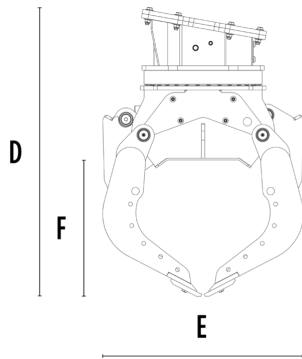
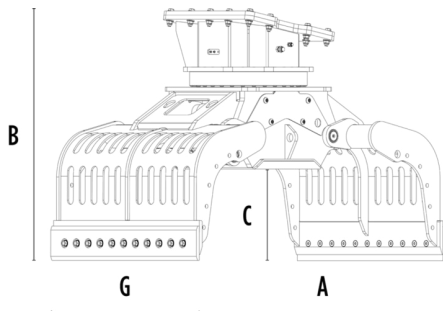

## SPECIFICATIONS

Recommended excavator	ton	18 - 30
Weight	ton	1,65
Capacity (claws closed)	m <sup>3</sup>	0,71
Rotation	Degree	360°
Oil pressure (rotation)	bar	200 - 250
Oil flow rate (rotation)	l/min	30 - 40
Maximum oil pressure (opening - closing)	bar	300 - 350
Maximum oil flow rate (opening - closing)	l/min	70 - 90
Size A	mm	2115
Size B	mm	1450
Size C	mm	590
Size D	mm	1670
Size E	mm	1185
Size F	mm	810
Size G	mm	1235

## OPTIONAL ACCESSORIES

Multi-purpose blade kit	Clam shell kit
Grip improvement kit	Rubber protection kit
Rotation power extender kit	Electrical kit (for 2 hose functionality) 12 V
Remote power control system	24 Month warranty

## APPLICATION AREAS



Demolitions



Road works



Quarry



Mines



Tunnels



Enclosed spaces



Pipelines



Urban construction site



Maintaining landscape and agricultural areas



Forest Maintenance

