

# PINZA SELECCIONADORA MB-G400 S4

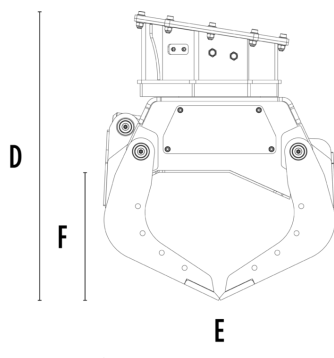

## CARACTERÍSTICAS TÉCNICAS

Excavadora aconsejada	lb	5,290 - 8,820
Peso	lb	441
Capacidad (garras cerradas)	cy	0.1
Rotación	Degree	360°
Presión del aceite (rotación)	PSI	1,885 - 2,466
Caudal de aceite (rotación)	gal/min	2 - 3
Presión de aceite máxima (apertura - cierre)	PSI	2,611 - 3,191
Caudal de aceite máximo (apertura - cierre)	gal/min	5 - 7
Dimensión A	in	41
Dimensión B	in	31
Dimensión C	in	13
Dimensión D	in	32
Dimensión E	in	27
Dimensión F	in	15
Dimensión G	in	16

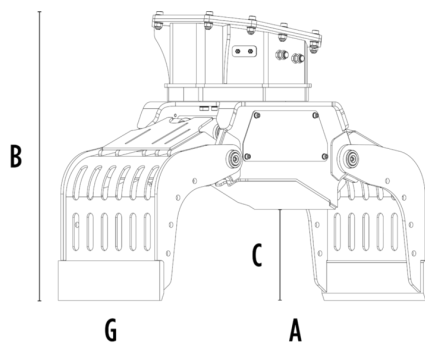

## ACCESORIOS OPCIONALES

Kit de cobertura para contención de garras	Kit placas laterales dentadas
Kit eléctrico (para funcionalidad dos tubos) 12 V	Garantía de 24 meses

## ÁREAS DE APLICACIÓN



Demoliciones



Obras viales



Galerías



Ambientes cerrados



Canalizaciones



Obras urbanas



Mantenimiento de  
áreas verdes y  
agrícolas



Mantenimiento de  
áreas forestales