

SORTEERGRIJPER MB-G500 S4

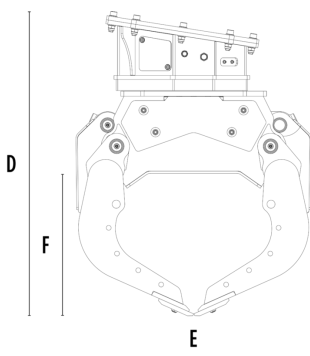

TECHNISCHE EIGENSCHAPPEN

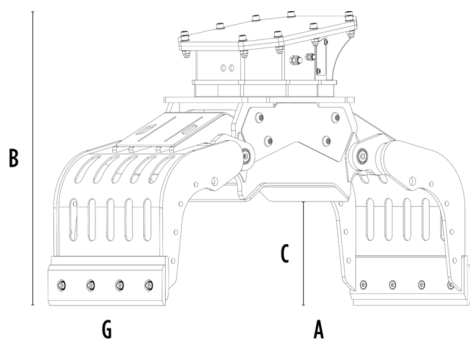

Aanbevolen graafmachine	ton	5 - 8
Eigen gewicht	ton	0,42
Inhoud (gesloten schalen)	m ³	0,18
Rotatie	Graden	360°
Werkdruk (rotatie)	bar	160 - 200
Olieflow (rotatie)	l/min	15 - 25
Werkdruk max. (openen - sluiten)	bar	180 - 250
Olieflow max. (openen - sluiten)	l/min	30 - 40
Afmeting A	mm	1500
Afmeting B	mm	980
Afmeting C	mm	415
Afmeting D	mm	1095
Afmeting E	mm	855
Afmeting F	mm	530
Afmeting G	mm	555

OPTIONELE ACCESSOIRES

Onderschroefmessen met tanden en glad mes, omkeerbaar	Set platen om schalen dicht te maken
Zijplaten met tanden	Opschroefblokken met tanden voor extra grip binnenkant
Zelfpositionerende klemrubbers	Electrisch bediend wisselventiel om roteren en openenen/sluiten via één extra functie te bedienen, 12 V

TOEPASSINGEN

