

PINCE DE TRI

MB-G500 S4



CARACTÉRISTIQUES TECHNIQUES

Pelle hydraulique recommandée	tonne	5 - 8
Poids	tonne	0,42
Capacité (griffes fermées)	m ³	0,18
Rotation	Degrés	360°
Pression d'huile (rotation)	bar	160 - 200
Débit d'huile (rotation)	l/min	15 - 25
Pression d'huile maximale (ouverture - fermeture)	bar	180 - 250
Débit d'huile maximum (ouverture - fermeture)	l/min	30 - 40
Dimension A	mm	1500
Dimension B	mm	980
Dimension C	mm	415
Dimension D	mm	1095
Dimension E	mm	855
Dimension F	mm	530
Dimension G	mm	555

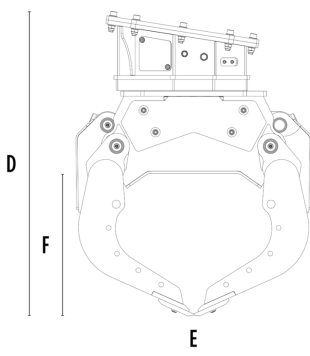
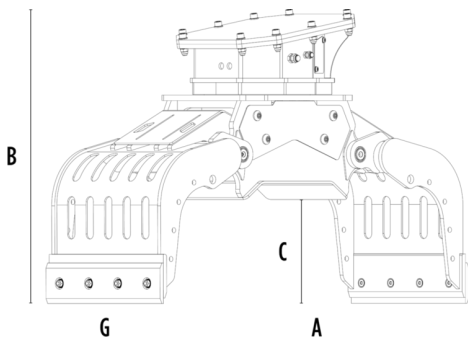

OPTIONS

Kit de lames multifonctions	Kit benne preneuse
Kit plaque latérale dentée	Kit amélioration préhension interne
Kit soulèvement basculant avec profils en caoutchouc	Kit inverseur électrique (nécessaire pour pelle ayant 1 seule ligne) 12 V

DOMAINES D'APPLICATION



Démolitions



Travaux routiers



Tunnels



Lieux clos



Canalisations



Chantiers urbains



Entretien des espaces
verts et agricoles



Entretien des zones
forestières

