

PINCE DE TRI MB-G1200 S4

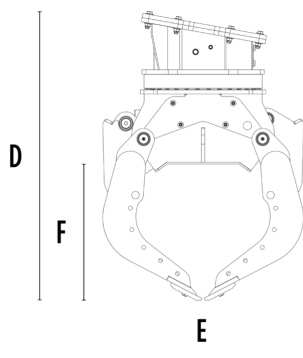

CARACTÉRISTIQUES TECHNIQUES

Pelle hydraulique recommandée	tonne	18 - 30
Poids	tonne	1,65
Capacité (griffes fermées)	m ³	0,71
Rotation	Degrés	360°
Pression d'huile (rotation)	bar	200 - 250
Débit d'huile (rotation)	l/min	30 - 40
Pression d'huile maximale (ouverture - fermeture)	bar	300 - 350
Débit d'huile maximum (ouverture - fermeture)	l/min	70 - 90
Dimension A	mm	2115
Dimension B	mm	1450
Dimension C	mm	590
Dimension D	mm	1670
Dimension E	mm	1185
Dimension F	mm	810
Dimension G	mm	1235

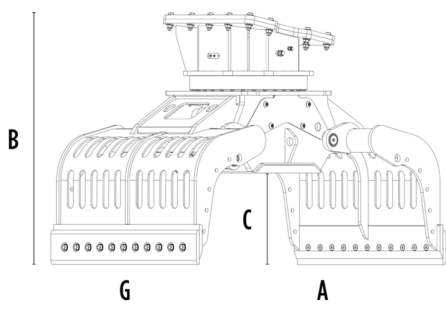

OPTIONS

Kit de lames multifonctions	Kit benne preneuse
Kit amélioration préhension interne	Kit soulèvement basculant avec profils en caoutchouc
Kit multiplicateur de force de rotation	
Remote power control system	Garantie de 24 mois

DOMAINES D'APPLICATION



Démolitions



Travaux routiers



Carrières



Mines



Tunnels



Lieux clos



Canalisations



Chantiers urbains



Entretien des espaces
verts et agricoles



Entretien des zones
forestières

