

PINCE DE TRI

MB-G400 S4

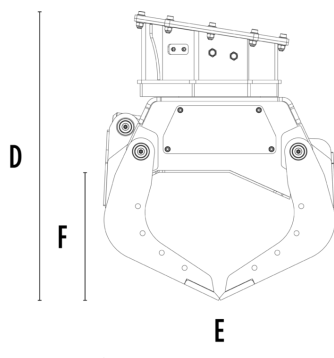
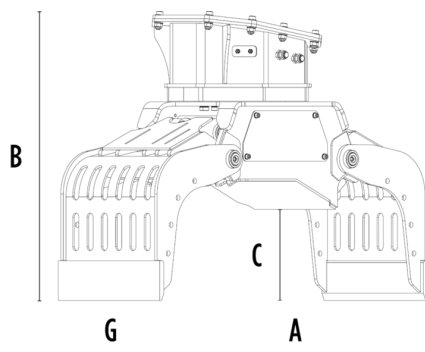

CARACTÉRISTIQUES TECHNIQUES

Pelle hydraulique recommandée	lb	5,290 - 8,820
Poids	lb	441
Capacité (griffes fermées)	cy	0.1
Rotation	Degree	360°
Pression d'huile (rotation)	PSI	1,885 - 2,466
Débit d'huile (rotation)	gal/min	2 - 3
Pression d'huile maximale (ouverture - fermeture)	PSI	2,611 - 3,191
Débit d'huile maximum (ouverture - fermeture)	gal/min	5 - 7
Dimension A	in	41
Dimension B	in	31
Dimension C	in	13
Dimension D	in	32
Dimension E	in	27
Dimension F	in	15
Dimension G	in	16

OPTIONS

Kit benne preneuse	Kit plaque latérale dentée
Kit inverseur électrique (nécessaire pour pelle ayant 1 seule ligne) 12 V	Garantie de 24 mois

DOMAINES D'APPLICATION



Démolitions



Travaux routiers



Tunnels



Lieux clos



Canalisations



Chantiers urbains



Entretien des espaces
verts et agricoles



Entretien des zones
forestières