

# SORTEERGRIJPER MB-G500 S4

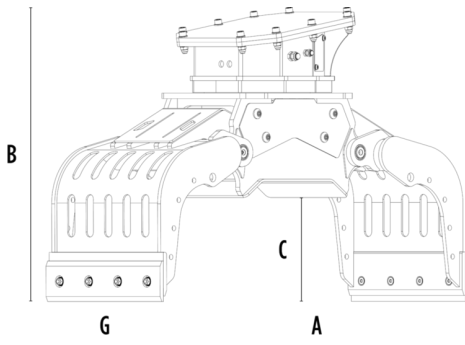

## TECHNISCHE EIGENSCHAPPEN

Aanbevolen graafmachine	lb	11,020 - 17,640
Eigen gewicht	lb	926
Inhoud (gesloten schalen)	cy	0.24
Rotatie	Degree	360°
Werkdruk (rotatie)	PSI	2,321 - 2,901
Olieflow (rotatie)	gal/min	4 - 7
Maximale werkdruk (openen - sluiten)	PSI	2,611 - 3,626
Maximale olieflow (openen - sluiten)	gal/min	8 - 11
Afmeting A	in	59
Afmeting B	in	39
Afmeting C	in	16
Afmeting D	in	43
Afmeting E	in	34
Afmeting F	in	21
Afmeting G	in	22



G

A

## OPTIONELE ACCESSOIRES

Underschroefmessen met tanden en glad mes, omkeerbaar	Set platen om schalen dicht te maken
Zijplaten met tanden	Opschroefblokken met tanden voor extra grip binnenkant
Zelfpositionerende klemrubbers	Electrisch bediend wisselventiel om roteren en openen/sluiten via één extra functie te bedienen, 12 V

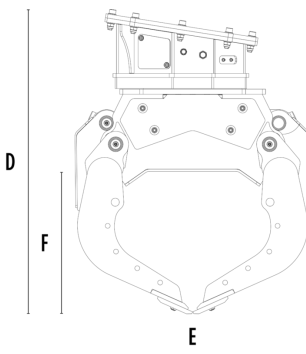

D

F

E

## TOEPASSINGEN



Sloopwerkzaamheden



Wegenbouw



Tunnelbouw



Krappe ruimtes



Leiding- en kabelwerken



Binnenstedelijke bouwplaatsen



Omgevingswerken



Bosonderhoud

