

SORTING GRAPPLE

MB-G600 S4

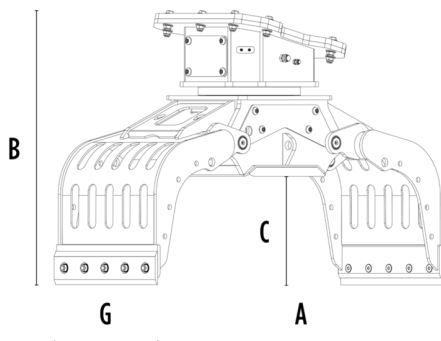

G A

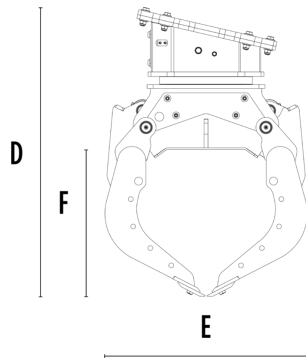

D F E



SPECIFICATIONS

Recommended excavator	ton	7 - 12
Weight	ton	0,63
Capacity (claws closed)	m ³	0,24
Rotation	Degree	360°
Oil pressure (rotation)	bar	160 - 200
Oil flow rate (rotation)	l/min	25 - 35
Maximum oil pressure (opening - closing)	bar	250 - 300
Maximum oil flow rate (opening - closing)	l/min	50 - 60
Size A	mm	1705
Size B	mm	1145
Size C	mm	470
Size D	mm	1300
Size E	mm	975
Size F	mm	625
Size G	mm	650

OPTIONAL ACCESSORIES

Multi-purpose blade kit	Clam shell kit
Serrated side plate kit	Grip improvement kit
Rubber protection kit	Rotation power extender kit
Electrical kit (for 2 hose functionality) 12 V	Remote power control system

APPLICATION AREAS



Demolitions



Road works



Quarry



Mines



Tunnels



Enclosed spaces



Pipelines



Urban construction site



Maintaining landscape and agricultural areas



Forest Maintenance