

# SORTING GRAPPLE

# MB-G1200 S4

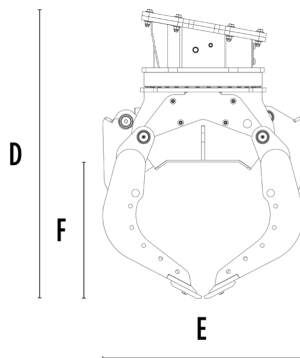
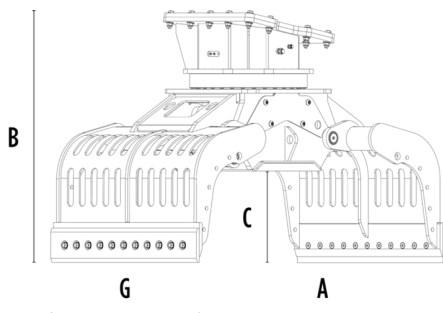

## SPECIFICATIONS

Recommended excavator	lb	39,680 - 66,140
Weight	lb	3,637
Capacity (claws closed)	cy	0.93
Rotation	Degree	360°
Oil pressure (rotation)	PSI	2,901 - 3,626
Oil flow rate (rotation)	gal/min	8 - 11
Maximum oil pressure (opening - closing)	PSI	4,351 - 5,076
Maximum oil flow rate (opening - closing)	gal/min	18 - 24
Size A	in	83
Size B	in	57
Size C	in	23
Size D	in	66
Size E	in	47
Size F	in	32
Size G	in	49

## OPTIONAL ACCESSORIES

Multi-purpose blade kit	Clam shell kit
Grip improvement kit	Rubber protection kit
Rotation power extender kit	Electrical kit (for 2 hose functionality) 12 V
Remote power control system	

## APPLICATION AREAS

