

# CRUSHER BUCKET MB-C50 S4

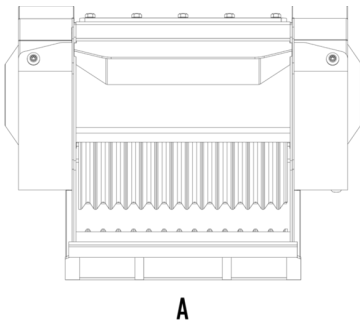

A

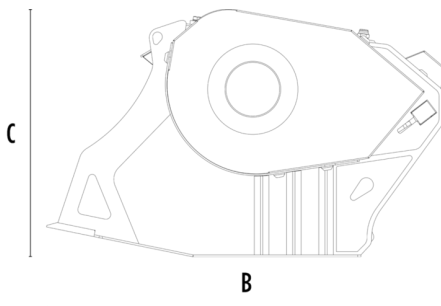

B



## SPECIFICATIONS



Recommended excavator	ton	6,5 - 10
Recommended backhoe loader	ton	8 - 9*
Weight	ton	0,75
Load capacity	m <sup>3</sup>	0.15
Pressure	bar	200 - 250
Back pressure	bar	< 10
Oil flow rate**	l/min	90 - 120
Mouth width	mm	590
Mouth height	mm	280
Size A	mm	1000
Size B	mm	1240
Size C	mm	770

\* Applicable only on the rear arm of the backhoe.

\*\* The minimum hydraulic flow rate value must be alongside the required operating pressure

## OPTIONAL ACCESSORIES

Dust suppression kit

Hour meter

## APPLICATION AREAS



Demolitions



Road works



Tunnels



Enclosed spaces



Pipelines



Recycling aggregates



Urban construction site



Forest Maintenance