

SORTING GRAPPLE

MB-G400 S4

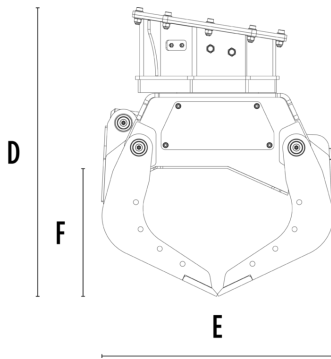
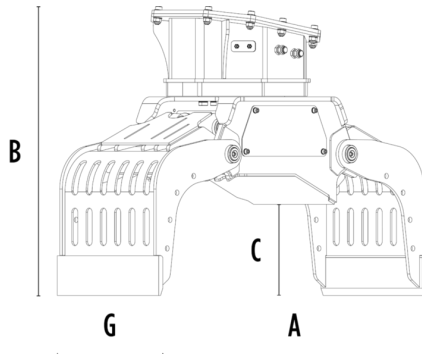

SPECIFICATIONS

Recommended excavator	lb	5,290 - 8,820
Weight	lb	441
Capacity (claws closed)	cy	0.1
Rotation	Degree	360°
Oil pressure (rotation)	PSI	1,885 - 2,466
Oil flow rate (rotation)	gal/min	2 - 3
Maximum oil pressure (opening - closing)	PSI	2,611 - 3,191
Maximum oil flow rate (opening - closing)	gal/min	5 - 7
Size A	in	41
Size B	in	31
Size C	in	13
Size D	in	32
Size E	in	27
Size F	in	15
Size G	in	16

OPTIONAL ACCESSORIES

Clam shell kit	Serrated side plate kit
Electrical kit (for 2 hose functionality) 12 V	24 Month warranty

APPLICATION AREAS

