

# SORTIERGREIFER MB-G1200 S4

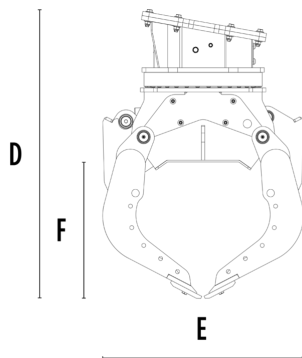
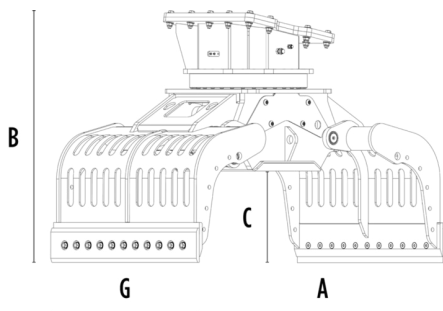

## TECHNISCHE EIGENSCHAFTEN

Empfohlener Bagger	t	18 - 30
Gewicht	t	1,65
Volumen (geschlossene Schalen)	m <sup>3</sup>	0,71
Rotation	Grad	360°
Benötigter Arbeitsdruck (Rotation)	bar	200 - 250
Öldurchfluss (Rotation)	l/min	30 - 40
Benötigter Arbeitsdruck max. (öffnen/schließen)	bar	300 - 350
Öldurchfluss max. (öffnen/schließen)	l/min	70 - 90
Abmessung A	mm	2115
Abmessung B	mm	1450
Abmessung C	mm	590
Abmessung D	mm	1670
Abmessung E	mm	1185
Abmessung F	mm	810
Abmessung G	mm	1235

## ZUBEHÖR

Schneidmesser-Kit mit Zähnen	Kit Schalenabdeckung
Kit-Greifverbesserung des Schaleninneren	Hebe-Kit mit Gummiprofilen
Drehkraftvervielfältigungs-Kit	
Remote power control system	24-monatige Garantie

## ANWENDUNGSBEREICHE



Abrisse



Strassenarbeiten



Steinbrüche



Minen



Tunnel



Geschlossene Umgebungen



Kanalisierung



Städtische Baustellen



Pflege von Grün- und Landwirtschaftsflächen



Pflege von Waldgebieten

