

SORTING GRAPPLE

MB-G400 S4

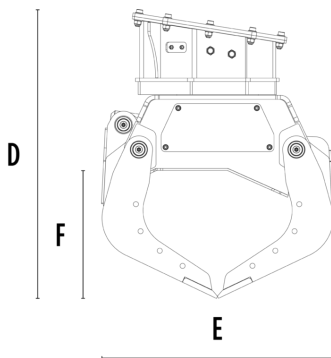
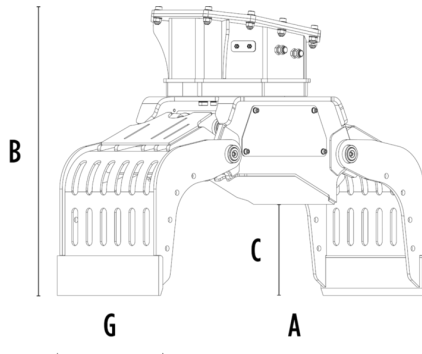

SPECIFICATIONS

| | | |
|-------------------------------------------|---------|---------------|
| Recommended excavator | lb | 5,290 - 8,820 |
| Weight | lb | 441 |
| Capacity (claws closed) | cy | 0.1 |
| Rotation | Degree | 360° |
| Oil pressure (rotation) | PSI | 1,885 - 2,466 |
| Oil flow rate (rotation) | gal/min | 2 - 3 |
| Maximum oil pressure (opening - closing) | PSI | 2,611 - 3,191 |
| Maximum oil flow rate (opening - closing) | gal/min | 5 - 7 |
| Size A | in | 41 |
| Size B | in | 31 |
| Size C | in | 13 |
| Size D | in | 32 |
| Size E | in | 27 |
| Size F | in | 15 |
| Size G | in | 16 |

OPTIONAL ACCESSORIES

| | |
|------------------------------------------------|-------------------------|
| Clam shell kit | Serrated side plate kit |
| 12 V Electrical Kit (for 2 hose functionality) | 24 Month Warranty |

APPLICATION AREAS



Demolitions



Road works



Tunnels



Enclosed spaces



Pipelines



Urban construction sites



Maintaining landscape and agricultural areas



Forest maintenance