

# CRUSHER BUCKET MB-C50 S4

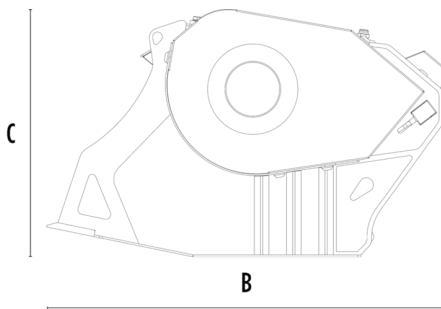

## SPECIFICATIONS

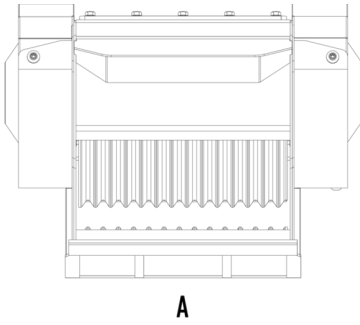

Recommended excavator	lb	14,330 - 22,050
Recommended backhoe loader	lb	17,640 - 19,840*
Weight	lb	1,653
Load capacity	cy	0.20
Pressure	PSI	2,901 - 3,626
Back pressure	PSI	< 145
Oil flow rate**	gal/min	24 - 32
Mouth width	in	23
Mouth height	in	11
Size A	in	39
Size B	in	49
Size C	in	30

\* Applicable only on the rear arm of the backhoe.

\*\* The minimum hydraulic flow rate value must be alongside the required operating pressure

## OPTIONAL ACCESSORIES

Dust suppression kit

Hour meter

24 Month warranty

## APPLICATION AREAS



Demolitions



Road works



Tunnels



Enclosed spaces



Pipelines



Recycling aggregates



Urban construction site



Forest Maintenance

