

# PINZA SELEZIONATRICE MB-G1000 S4

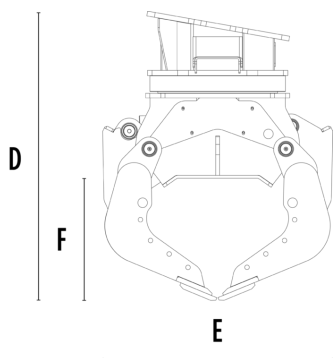
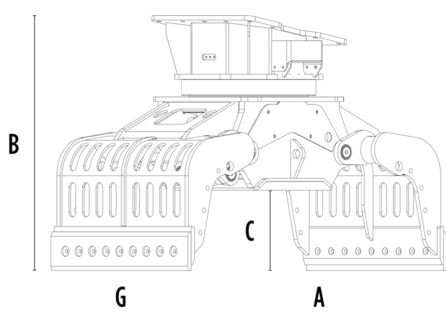

## CARATTERISTICHE TECNICHE

Escavatore consigliato	ton	18 - 25
Peso	ton	1,62
Capacità (chele chiuse)	m <sup>3</sup>	0,44
Rotazione	Grado	360°
Pressione d'olio (rotazione)	bar	200 - 250
Portata d'olio (rotazione)	l/min	60 - 80
Pressione d'olio massima (apertura - chiusura)	bar	300 - 350
Portata d'olio massima (apertura - chiusura)	l/min	70 - 90
Dimensione A	mm	1860
Dimensione B	mm	1375
Dimensione C	mm	510
Dimensione D	mm	1500
Dimensione E	mm	1200
Dimensione F	mm	640
Dimensione G	mm	1015

## ACCESSORI OPZIONALI

Remote power control system

Garanzia 24 mesi

## AREE DI APPLICAZIONE



Demolizioni



Lavori stradali



Cave



Miniere



Gallerie



Ambienti chiusi



Canalizzazioni



Cantieri urbani



Manutenzione aree verdi e agricole



Manutenzione aree forestali

