

# PINÇA SELECIONADORA MB-G900 S4

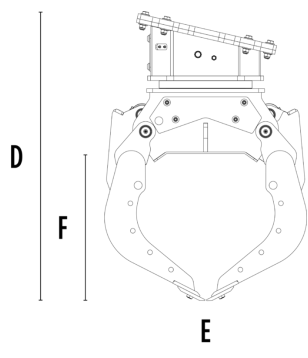
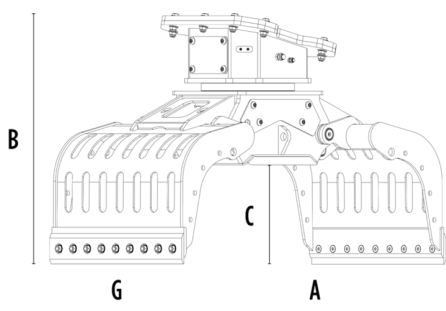

## CARACTERÍSTICAS TÉCNICAS

Escavadora recomendada	lb	26,460 - 39,680
Peso	lb	1,72
Capacidade (garras fechadas)	cy	0.56
Rotação	Degree	360°
Pressão do óleo (rotação)	PSI	2,321 - 3,191
Fluxo de óleo (rotação)	gal/min	4 - 9
Pressão máxima de óleo (abertura - fechamento)	PSI	4,351 - 5,076
Fluxo máximo de óleo (abertura - fechamento)	gal/min	16 - 18
Dimensão A	in	73
Dimensão B	in	48
Dimensão C	in	21
Dimensão D	in	56
Dimensão E	in	39
Dimensão F	in	29
Dimensão G	in	37

## ACESSÓRIOS OPCIONAIS EXTRAS

Kit de lâminas multifunções	Kit de cobertura contenção de garras
Kit de bloqueio lateral (com conjunto de dentes)	Kit de melhoria do aperto das garras internas
Kit elevador inclinado com perfis de borracha	Kit multiplicador de força de rotação
Kit de desviador elétrico (função de duas mangueiras) 12 V	Remote power control system
Garantia de 24 meses	

## ÁREAS DE APLICAÇÃO



Demolições



Obras rodoviárias



Pedreiras



Minas



Túneis



Ambientes fechados



Canalizações



Estaleiros urbanos



Manutenção de áreas verdes e agrícolas



Manutenção de áreas florestais

