

# PINCE DE TRI MB-G600 S4

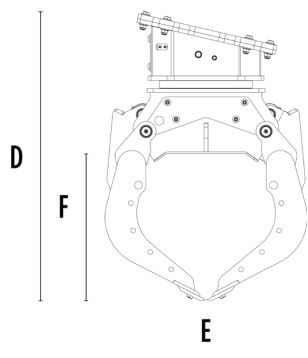
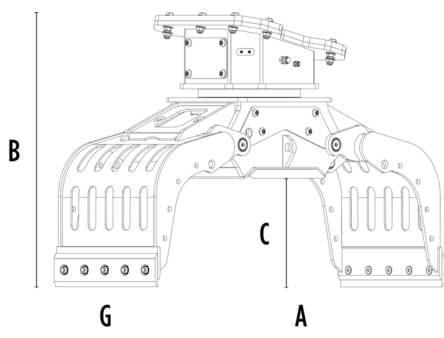

## CARACTÉRISTIQUES TECHNIQUES

Pelle hydraulique recommandée	tonne	7 - 12
Poids	tonne	0,63
Capacité (griffes fermées)	m <sup>3</sup>	0,24
Rotation	Degrés	360°
Pression d'huile (rotation)	bar	160 - 200
Débit d'huile (rotation)	l/min	25 - 35
Pression d'huile maximale (ouverture - fermeture)	bar	250 - 300
Débit d'huile maximum (ouverture - fermeture)	l/min	50 - 60
Dimension A	mm	1705
Dimension B	mm	1145
Dimension C	mm	470
Dimension D	mm	1300
Dimension E	mm	975
Dimension F	mm	625
Dimension G	mm	650

## OPTIONS

Kit de lames multifonctions	Kit benne preneuse
Kit plaque latérale dentée	Kit amélioration préhension interne
Kit soulèvement basculant avec profils en caoutchouc	Kit multiplicateur de force de rotation
Kit inverseur électrique (nécessaire pour pelle ayant 1 seule ligne) 12 V	Remote power control system

## DOMAINES D'APPLICATION



Démolitions



Travaux routiers



Carrières



Mines



Tunnels



Lieux clos



Canalisations



Chantiers urbains



Entretien des espaces  
verts et agricoles



Entretien des zones  
forestières

