

# SORTING GRAPPLE

# MB-G1000 S4

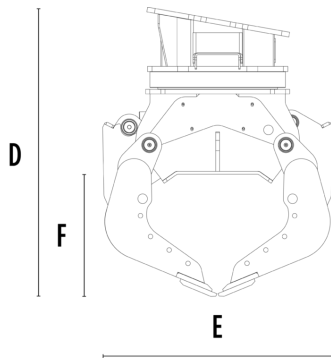
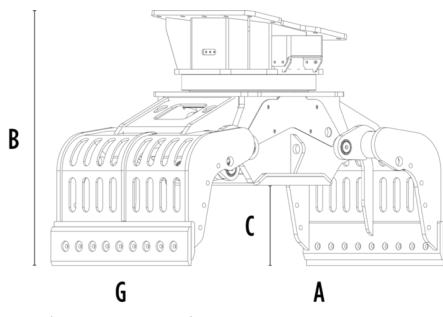

## SPECIFICATIONS

Recommended excavator	ton	18 - 25
Weight	ton	1,62
Capacity (claws closed)	m <sup>3</sup>	0,44
Rotation	Degree	360°
Oil pressure (rotation)	bar	200 - 250
Oil flow rate (rotation)	l/min	60 - 80
Maximum oil pressure (opening - closing)	bar	300 - 350
Maximum oil flow rate (opening - closing)	l/min	70 - 90
Size A	mm	1860
Size B	mm	1375
Size C	mm	510
Size D	mm	1500
Size E	mm	1200
Size F	mm	640
Size G	mm	1015

## OPTIONAL ACCESSORIES

Remote power control system

24 Month warranty

## APPLICATION AREAS



Demolitions



Road works



Quarry



Mines



Tunnels



Enclosed spaces



Pipelines



Urban construction site



Maintaining landscape and agricultural areas



Forest Maintenance

