

PINZA SELEZIONATRICE MB-G1200 S4

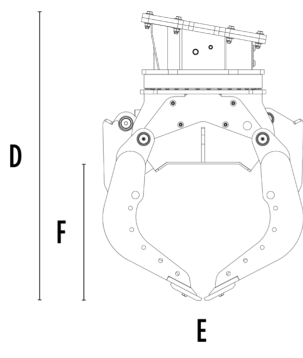
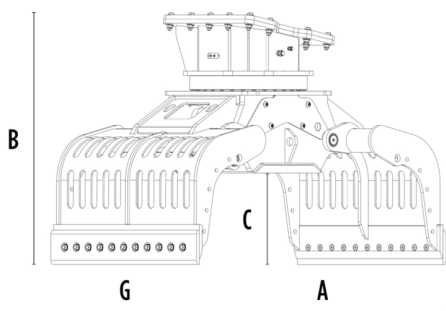

CARATTERISTICHE TECNICHE

Escavatore consigliato	ton	18 - 30
Peso	ton	1,65
Capacità (chele chiuse)	m ³	0,71
Rotazione	Grado	360°
Pressione d'olio (rotazione)	bar	200 - 250
Portata d'olio (rotazione)	l/min	30 - 40
Pressione d'olio massima (apertura - chiusura)	bar	300 - 350
Portata d'olio massima (apertura - chiusura)	l/min	70 - 90
Dimensione A	mm	2115
Dimensione B	mm	1450
Dimensione C	mm	590
Dimensione D	mm	1670
Dimensione E	mm	1185
Dimensione F	mm	810
Dimensione G	mm	1235

ACCESSORI OPZIONALI

Kit lame multifunzione	Kit copertura contenimento chele
Kit miglioramento presa interno chele	Kit sollevamento basculante con profili in gomma
Kit moltiplicatore di forza rotazione	Kit elettrico (per funzionalità due tubi) 12 V
Remote power control system	Garanzia 24 mesi

AREE DI APPLICAZIONE



Demolizioni



Lavori stradali



Cave



Miniere



Gallerie



Ambienti chiusi



Canalizzazioni



Cantieri urbani



Manutenzione aree verdi e agricole



Manutenzione aree forestali

