

SORTIERGREIFER MB-G400 S4

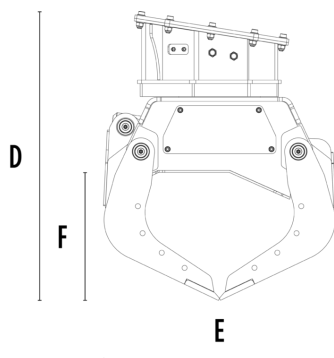

TECHNISCHE EIGENSCHAFTEN

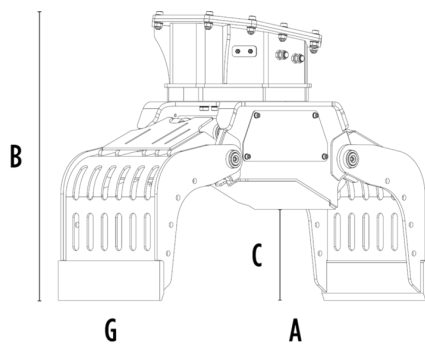

Empfohlener Bagger	t	2,4 - 4
Gewicht	t	0,2
Volumen (geschlossene Schalen)	m ³	0,07
Rotation	Grad	360°
Benötigter Arbeitsdruck (Rotation)	bar	130 - 170
Öldurchfluss (Rotation)	l/min	8 - 12
Benötigter Arbeitsdruck max. (öffnen/schließen)	bar	180 - 220
Öldurchfluss max. (öffnen/schließen)	l/min	20 - 25
Abmessung A	mm	1050
Abmessung B	mm	780
Abmessung C	mm	330
Abmessung D	mm	825
Abmessung E	mm	675
Abmessung F	mm	375
Abmessung G	mm	400

ZUBEHÖR

Kit Schalenabdeckung

Kit-Seitenabdeckung mit Zähnen

Elektro-Kit(für Zwei-Schlauch-Funktionalität) 12 V

24-monatige Garantie

ANWENDUNGSBEREICHE



Abrisse



Strassenarbeiten



Tunnel



Geschlossene Umgebungen



Kanalisierung



Städtische Baustellen



Pflege von Grün- und Landwirtschaftsflächen



Pflege von Waldgebieten