

PINÇA SELECIONADORA MB-G1000 S4

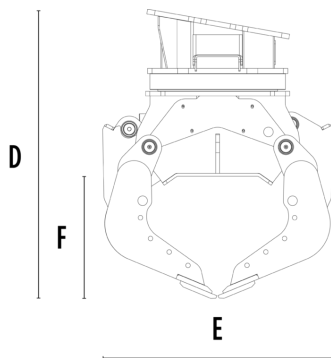
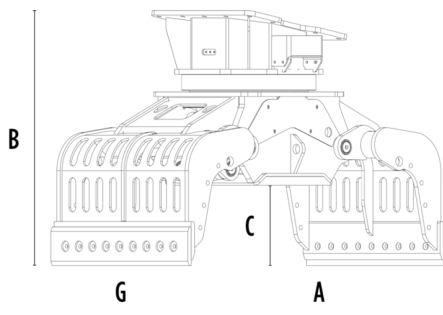

CARACTERÍSTICAS TÉCNICAS

Escavadora recomendada	lb	39,680 - 55,120
Peso	lb	3,257
Capacidade (garras fechadas)	cy	0.58
Rotação	Degree	360°
Pressão do óleo (rotação)	PSI	2,901 - 3,626
Fluxo de óleo (rotação)	gal/min	16 - 21
Pressão máxima de óleo (abertura - fechamento)	PSI	4,351 - 5,076
Fluxo máximo de óleo (abertura - fechamento)	gal/min	18 - 24
Dimensão A	in	73
Dimensão B	in	54
Dimensão C	in	20
Dimensão D	in	59
Dimensão E	in	47
Dimensão F	in	25
Dimensão G	in	40

ACESSÓRIOS OPCIONAIS EXTRAS

Remote power control system

Garantia de 24 meses

ÁREAS DE APLICAÇÃO



Demolições



Obras rodoviárias



Pedreiras



Minas



Túneis



Ambientes fechados



Canalizações



Estaleiros urbanos



Manutenção de áreas verdes e agrícolas



Manutenção de áreas florestais

