

PINCE DE TRI MB-G900 S4

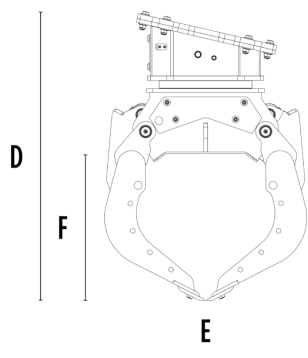

CARACTÉRISTIQUES TECHNIQUES

Pelle hydraulique recommandée	tonne	12 - 18
Poids	tonne	0,78
Capacité (griffes fermées)	m ³	0,43
Rotation	Degrés	360°
Pression d'huile (rotation)	bar	160 - 220
Débit d'huile (rotation)	l/min	25 - 35
Pression d'huile maximale (ouverture - fermeture)	bar	300 - 350
Débit d'huile maximum (ouverture - fermeture)	l/min	60 - 70
Dimension A	mm	1860
Dimension B	mm	1210
Dimension C	mm	540
Dimension D	mm	1410
Dimension E	mm	1000
Dimension F	mm	740
Dimension G	mm	930

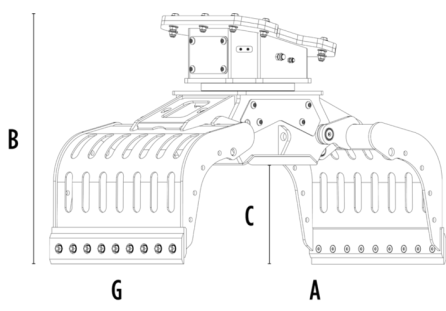

OPTIONS

Kit de lames multifonctions	Kit benne preneuse
Kit plaque latérale dentée	Kit amélioration préhension interne
Kit soulèvement basculant avec profils en caoutchouc	Kit multiplicateur de force de rotation
	Remote power control system
Garantie de 24 mois	

DOMAINES D'APPLICATION



Démolitions



Lieux clos



Travaux routiers



Canalisations



Carrières



Chantiers urbains



Mines



Entretien des espaces
verts et agricoles



Tunnels



Entretien des zones
forestières

