

GODET CONCASSEUR MB-C50 S4

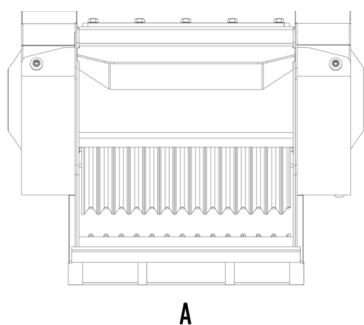

A

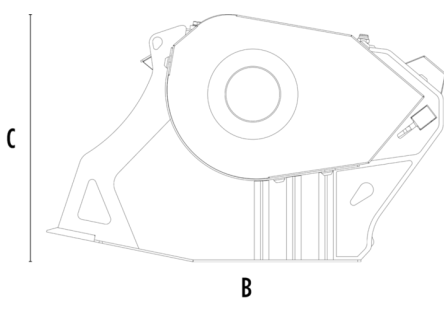

B

CARACTÉRISTIQUES TECHNIQUES



Pelle hydraulique recommandée

lb

14,330 - 22,050



Tractopelle recommandée

lb

17,640 - 19,840*

Poids

lb

1,653

Capacité de charge

cy

0.2

Pression

PSI

2,901 - 3,626

Contre-pression

PSI

< 145

Débit d'huile**

gal/min

24 - 32

Largeur de la bouche

in

23

Hauteur de la bouche

in

11

Dimension A

in

39

Dimension B

in

49

Dimension C

in

30

* Installable uniquement sur le bras arrière de la chargeuse-pelleteuse.

** La valeur du débit hydraulique minimum doit être obtenue en même temps que la pression du travail demandée.

OPTIONS

Brumisateur

Compteur

DOMAINES D'APPLICATION



Démolitions



Travaux routiers



Tunnels



Lieux clos



Canalisations



Recyclage des déchets inertes



Chantiers urbains



Entretien des zones forestières

