

PINZA SELECCIONADORA MB-G1000 S4

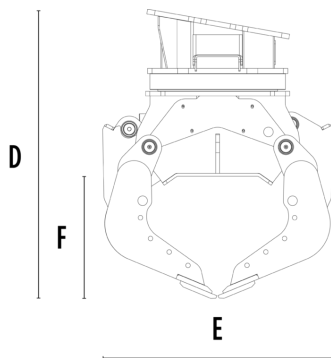
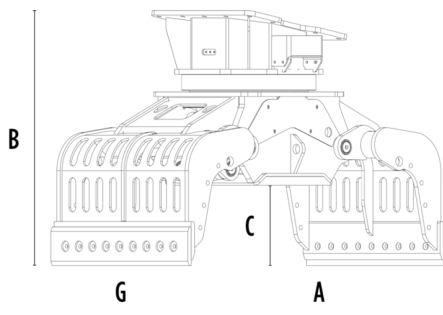

CARACTERÍSTICAS TÉCNICAS

Excavadora aconsejada	lb	39,680 - 55,120
Peso	lb	3,257
Capacidad (garras cerradas)	cy	0.58
Rotación	Degree	360°
Presión del aceite (rotación)	PSI	2,901 - 3,626
Caudal de aceite (rotación)	gal/min	16 - 21
Presión de aceite máxima (apertura - cierre)	PSI	4,351 - 5,076
Caudal de aceite máximo (apertura - cierre)	gal/min	18 - 24
Dimensión A	in	73
Dimensión B	in	54
Dimensión C	in	20
Dimensión D	in	59
Dimensión E	in	47
Dimensión F	in	25
Dimensión G	in	40

ACCESORIOS OPCIONALES

Remote power control system

Garantía de 24 meses

ÁREAS DE APLICACIÓN



Demoliciones



Obras viales



Canteras



Minas



Galerías



Ambientes cerrados



Canalizaciones



Obras urbanas



Mantenimiento de áreas verdes y agrícolas



Mantenimiento de áreas forestales

