

PINZA SELEZIONATRICE MB-G500 S4

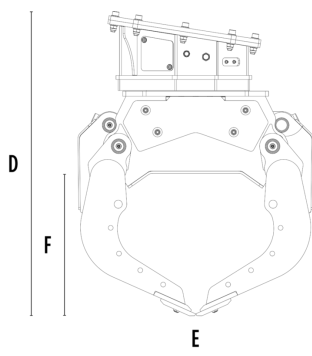

CARATTERISTICHE TECNICHE

Escavatore consigliato	lb	11,020 - 17,640
Peso	lb	926
Capacità (chele chiuse)	cy	0,24
Rotazione	Degree	360°
Pressione d'olio (rotazione)	PSI	2,321 - 2,901
Portata d'olio (rotazione)	gal/min	4 - 7
Pressione d'olio massima (apertura - chiusura)	PSI	2,611 - 3,626
Portata d'olio massima (apertura - chiusura)	gal/min	8 - 11
Dimensione A	in	59
Dimensione B	in	39
Dimensione C	in	16
Dimensione D	in	43
Dimensione E	in	34
Dimensione F	in	21
Dimensione G	in	22

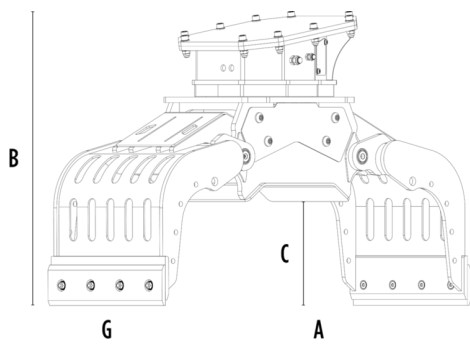

ACCESSORI OPZIONALI

Kit lame multifunzione	Kit copertura contenimento chele
Kit piastre laterali dentate	Kit miglioramento presa interno chele
Kit sollevamento basculante con profili in gomma	Kit elettrico (per funzionalità due tubi) 12 V
Garanzia 24 mesi	

AREE DI APPLICAZIONE



Demolizioni



Lavori stradali



Gallerie



Ambienti chiusi



Canalizzazioni



Cantieri urbani



Manutenzione aree verdi e agricole



Manutenzione aree forestali

