

PINCE DE TRI MB-G900 S4

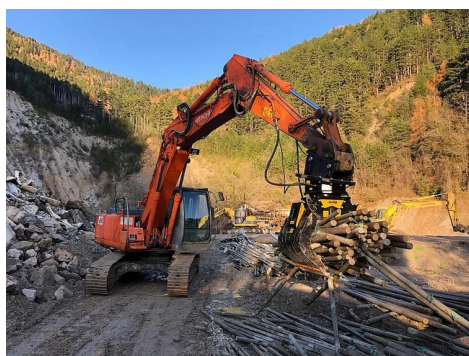

CARACTÉRISTIQUES TECHNIQUES

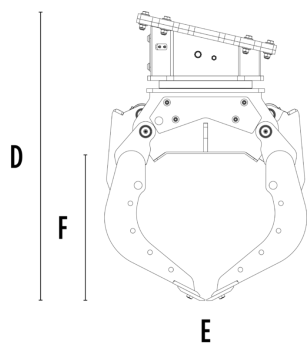
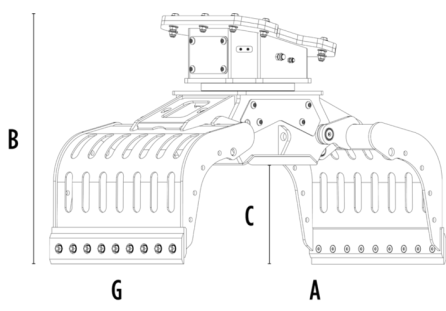

Pelle hydraulique recommandée	lb	26,460 - 39,680
Poids	lb	1,72
Capacité (griffes fermées)	cy	0,56
Rotation	Degree	360°
Pression d'huile (rotation)	PSI	2,321 - 3,191
Débit d'huile (rotation)	gal/min	4 - 9
Pression d'huile maximale (ouverture - fermeture)	PSI	4,351 - 5,076
Débit d'huile maximum (ouverture - fermeture)	gal/min	16 - 18
Dimension A	in	73
Dimension B	in	48
Dimension C	in	21
Dimension D	in	56
Dimension E	in	39
Dimension F	in	29
Dimension G	in	37

OPTIONS

Kit de lames multifonctions	Kit benne preneuse
Kit plaque latérale dentée	Kit amélioration préhension interne
Kit soulèvement basculant avec profils en caoutchouc	Kit multiplicateur de force de rotation
Kit inverseur électrique (nécessaire pour pelle ayant 1 seule ligne) 12 V	Remote power control system
Garantie de 24 mois	

DOMAINES D'APPLICATION



Démolitions



Lieux clos



Travaux routiers



Canalisations



Carrières



Chantiers urbains



Mines



Entretien des espaces
verts et agricoles



Tunnels



Entretien des zones
forestières