

# PINÇA SELECIONADORA MB-G1000 S4

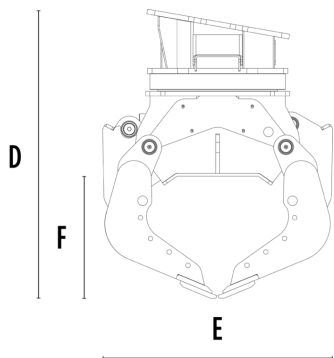

## CARACTERÍSTICAS TÉCNICAS

Escavadora recomendada	ton	18 - 25
Peso	ton	1,62
Capacidade (garras fechadas)	m <sup>3</sup>	0,44
Rotação	Grau	360°
Pressão do óleo (rotação)	bar	200 - 250
Fluxo de óleo (rotação)	l/min	60 - 80
Pressão máxima de óleo (abertura - fechamento)	bar	300 - 350
Fluxo máximo de óleo (abertura - fechamento)	l/min	70 - 90
Dimensão A	mm	1860
Dimensão B	mm	1375
Dimensão C	mm	510
Dimensão D	mm	1500
Dimensão E	mm	1200
Dimensão F	mm	640
Dimensão G	mm	1015

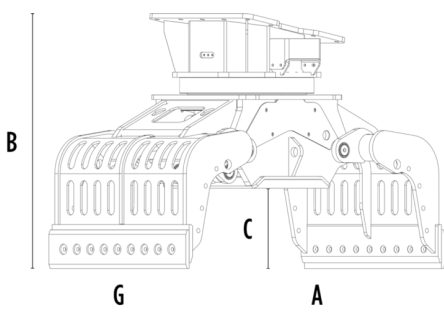

## ACESSÓRIOS OPCIONAIS EXTRAS

Remote power control system

Garantia de 24 meses

## ÁREAS DE APLICAÇÃO



Demolições



Obras rodoviárias



Pedreiras



Minas



Túneis



Ambientes fechados



Canalizações



Estaleiros urbanos



Manutenção de áreas verdes e agrícolas



Manutenção de áreas florestais

