

# PINCE DE TRI

# MB-G400 S4

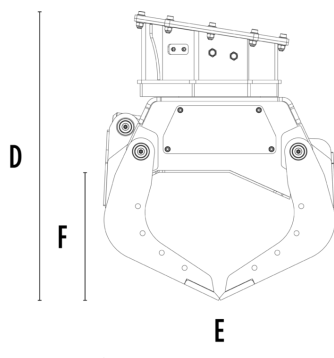
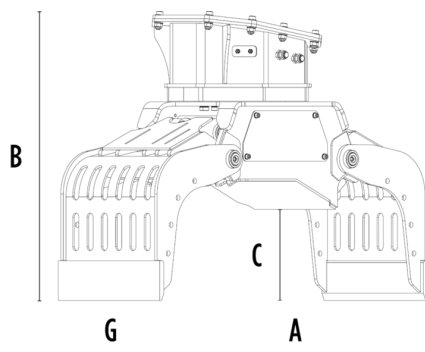

## CARACTÉRISTIQUES TECHNIQUES

Pelle hydraulique recommandée	tonne	2,4 - 4
Poids	tonne	0,2
Capacité (griffes fermées)	m <sup>3</sup>	0,07
Rotation	Degrés	360°
Pression d'huile (rotation)	bar	130 - 170
Débit d'huile (rotation)	l/min	8 - 12
Pression d'huile maximale (ouverture - fermeture)	bar	180 - 220
Débit d'huile maximum (ouverture - fermeture)	l/min	20 - 25
Dimension A	mm	1050
Dimension B	mm	780
Dimension C	mm	330
Dimension D	mm	825
Dimension E	mm	675
Dimension F	mm	375
Dimension G	mm	400

## OPTIONS

Kit benne preneuse	Kit plaque latérale dentée
	Garantie de 24 mois

## DOMAINES D'APPLICATION



Démolitions



Travaux routiers



Tunnels



Lieux clos



Canalisations



Chantiers urbains



Entretien des espaces  
verts et agricoles



Entretien des zones  
forestières