

PINCE DE TRI

MB-G500 S4



CARACTÉRISTIQUES TECHNIQUES

Pelle hydraulique recommandée	lb	11,020 - 17,640
Poids	lb	926
Capacité (griffes fermées)	cy	0.24
Rotation	Degree	360°
Pression d'huile (rotation)	PSI	2,321 - 2,901
Débit d'huile (rotation)	gal/min	4 - 7
Pression d'huile maximale (ouverture - fermeture)	PSI	2,611 - 3,626
Débit d'huile maximum (ouverture - fermeture)	gal/min	8 - 11
Dimension A	in	59
Dimension B	in	39
Dimension C	in	16
Dimension D	in	43
Dimension E	in	34
Dimension F	in	21
Dimension G	in	22

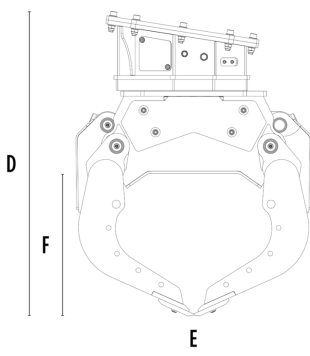
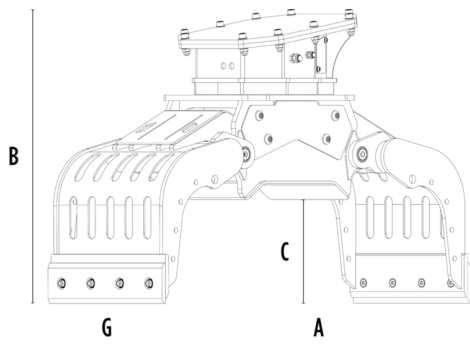

OPTIONS

Kit de lames multifonctions	Kit benne preneuse
Kit plaque latérale dentée	Kit amélioration préhension interne
Kit soulèvement basculant avec profils en caoutchouc	
Garantie de 24 mois	

DOMAINES D'APPLICATION



Démolitions



Travaux routiers



Tunnels



Lieux clos



Canalisations



Chantiers urbains



Entretien des espaces
verts et agricoles



Entretien des zones
forestières

