

PINCE DE TRI

MB-G1200 S4

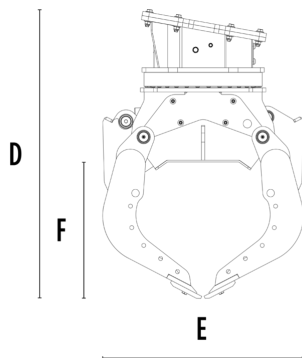
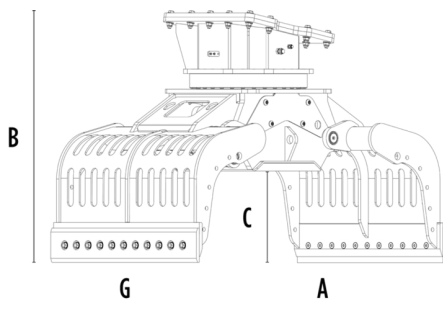

CARACTÉRISTIQUES TECHNIQUES

Pelle hydraulique recommandée	lb	39,680 - 66,140
Poids	lb	3,637
Capacité (griffes fermées)	cy	0.93
Rotation	Degree	360°
Pression d'huile (rotation)	PSI	2,901 - 3,626
Débit d'huile (rotation)	gal/min	8 - 11
Pression d'huile maximale (ouverture - fermeture)	PSI	4,351 - 5,076
Débit d'huile maximum (ouverture - fermeture)	gal/min	18 - 24
Dimension A	in	83
Dimension B	in	57
Dimension C	in	23
Dimension D	in	66
Dimension E	in	47
Dimension F	in	32
Dimension G	in	49

OPTIONS

Kit de lames multifonctions	Kit benne preneuse
Kit amélioration préhension interne	Kit soulèvement basculant avec profils en caoutchouc
Kit multiplicateur de force de rotation	
Remote power control system	Garantie de 24 mois

DOMAINES D'APPLICATION



Démolitions



Travaux routiers



Carrières



Mines



Tunnels



Lieux clos



Canalisations



Chantiers urbains



Entretien des espaces
verts et agricoles



Entretien des zones
forestières

