

# SORTING GRAPPLE

# MB-G400 S4

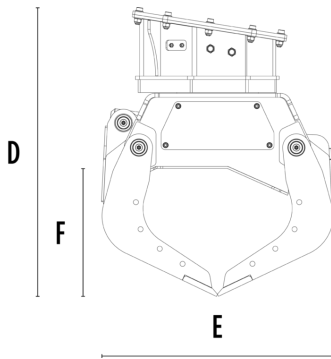
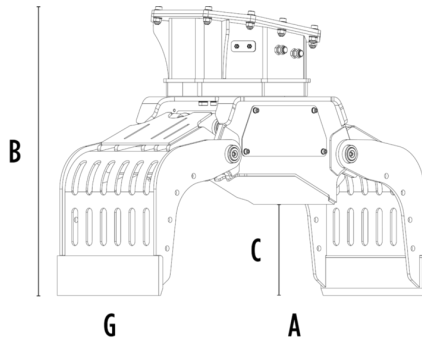

## SPECIFICATIONS

Recommended excavator	ton	2,4 - 4
Weight	ton	0,2
Capacity (claws closed)	m <sup>3</sup>	0,07
Rotation	Degree	360°
Oil pressure (rotation)	bar	130 - 170
Oil flow rate (rotation)	l/min	8 - 12
Maximum oil pressure (opening - closing)	bar	180 - 220
Maximum oil flow rate (opening - closing)	l/min	20 - 25
Size A	mm	1050
Size B	mm	780
Size C	mm	330
Size D	mm	825
Size E	mm	675
Size F	mm	375
Size G	mm	400

## OPTIONAL ACCESSORIES

Clam shell kit	Serrated side plate kit
Electrical kit (for 2 hose functionality) 12 V	24 Month warranty

## APPLICATION AREAS

