

SORTING GRAPPLE

MB-G450 S4

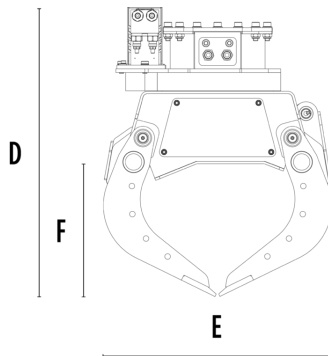

SPECIFICATIONS

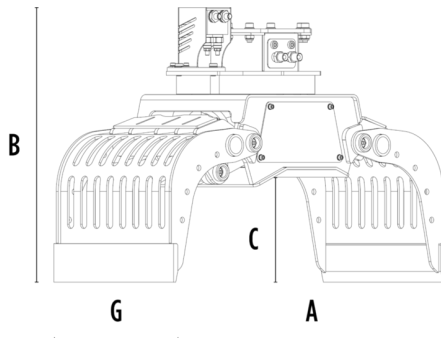

Recommended excavator	lb	7,720 - 12,120
Weight	lb	635
Capacity (claws closed)	cy	0.13
Rotation	Degree	360°
Oil pressure (rotation)	PSI	2,176 - 2,901
Oil flow rate (rotation)	gal/min	3 - 5
Maximum oil pressure (opening - closing)	PSI	2,611 - 3,191
Maximum oil flow rate (opening - closing)	gal/min	5 - 8
Size A	in	51
Size B	in	34
Size C	in	17
Size D	in	38
Size E	in	30
Size F	in	20
Size G	in	19

OPTIONAL ACCESSORIES

Multi-purpose blade kit	Clam shell kit
Serrated side plate kit	Grip improvement kit
Rubber protection kit	Electrical kit (for 2 hose functionality) 12 V
24 Month warranty	

APPLICATION AREAS



Demolitions



Road works



Tunnels



Enclosed spaces



Pipelines



Urban construction site



Maintaining landscape and agricultural areas



Forest Maintenance