

SORTIERGREIFER MB-G600 S4

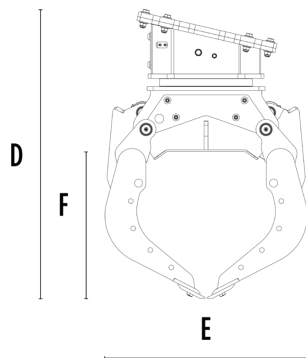
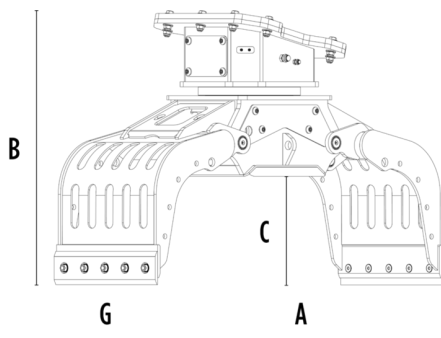

TECHNISCHE EIGENSCHAFTEN

Empfohlener Bagger	lb	15,430 - 26,460
Gewicht	lb	1,389
Volumen (geschlossene Schalen)	cy	0.31
Rotation	Degree	360°
Benötigter Arbeitsdruck (Rotation)	PSI	2,321 - 2,901
Öldurchfluss (Rotation)	gal/min	7 - 9
Benötigter Arbeitsdruck max. (öffnen/schließen)	PSI	3,626 - 4,351
Öldurchfluss max. (öffnen/schließen)	gal/min	13 - 16
Abmessung A	in	67
Abmessung B	in	45
Abmessung C	in	19
Abmessung D	in	51
Abmessung E	in	38
Abmessung F	in	25
Abmessung G	in	26

ZUBEHÖR

Schneidmesser-Kit mit Zähnen	Kit Schalenabdeckung
Kit-Seitenabdeckung mit Zähnen	Kit-Greifverbesserung des Schaleninneren
Hebe-Kit mit Gummiprofilen	Drehkraftvervielfältigungs-Kit
Elektro-Kit (für Zwei-Schlauch-Funktionalität) 12 V	Remote power control system

ANWENDUNGSBEREICHE



Abrisse



Strassenarbeiten



Steinbrüche



Minen



Tunnel



Geschlossene Umgebungen



Kanalisierung



Städtische Baustellen



Pflege von Grün- und Landwirtschaftsflächen



Pflege von Waldgebieten

