

# PINZA SELEZIONATRICE MB-G1200 S4

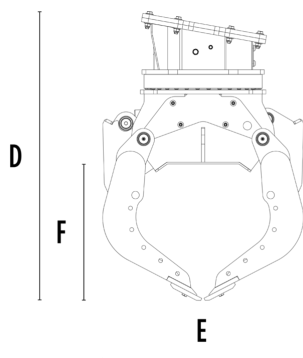
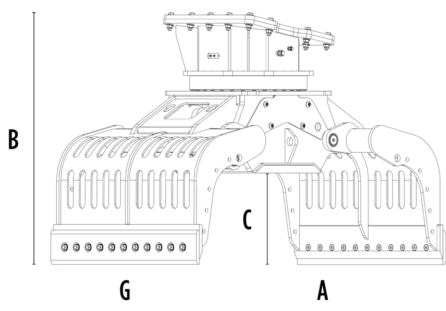

## CARATTERISTICHE TECNICHE

Escavatore consigliato	lb	39,680 - 66,140
Peso	lb	3,637
Capacità (chele chiuse)	cy	0.93
Rotazione	Degree	360°
Pressione d'olio (rotazione)	PSI	2,901 - 3,626
Portata d'olio (rotazione)	gal/min	8 - 11
Pressione d'olio massima (apertura - chiusura)	PSI	4,351 - 5,076
Portata d'olio massima (apertura - chiusura)	gal/min	18 - 24
Dimensione A	in	83
Dimensione B	in	57
Dimensione C	in	23
Dimensione D	in	66
Dimensione E	in	47
Dimensione F	in	32
Dimensione G	in	49

## ACCESSORI OPZIONALI

Kit lame multifunzione	Kit copertura contenimento chele
Kit miglioramento presa interno chele	Kit sollevamento basculante con profili in gomma
Kit moltiplicatore di forza rotazione	Kit elettrico (per funzionalità due tubi) 12 V
Remote power control system	Garanzia 24 mesi

## AREE DI APPLICAZIONE



Demolizioni



Lavori stradali



Cave



Miniere



Gallerie



Ambienti chiusi



Canalizzazioni



Cantieri urbani



Manutenzione aree verdi e agricole



Manutenzione aree forestali

